

ELECTRICAL RESUBMITTALS

SERVICE EQUIPMENT AND TRANSFORMERS



Electric Service, Inc.

**For the Battelle Biological and
Computational Sciences Facility**

Richland, WA.

2008

Owner:	Cowperwood Company
Architect:	Kaplan McLaughlin Diaz
Electrical Engineer:	Flack + Kurtz
General Contractor:	D.E. Harvey Builders
Electrical Contractor:	Magnum Electric Service, Inc.

Resubmittal

Section 26 24 13

Switchboards

Switchboard resubmittal synopsis:

- Part 2, 2.04 B – We are again submitting the main switchboards without insulated bussing. This is because it adds 4 to 6 weeks to the shipment time, and adds \$13,000.00 to the price. Square D does not make the type of insulation specified, theirs is a 7 mil tape, with no removable elbow pieces.
- Part 2, 2.04. C - Square D does not offer vertical busses that are fully rated. They provide the fully rated (4,000 amp) horizontal backbone, then tap from it into each section with 2,000 amps. Their representative told me that's because they can't load each vertical section up more than that anyway.
- Spare circuit breakers have been added to MS-BSF and MS-CSF as directed.
- 1,200 amp GFP chiller breakers have been added to MS-BSF and MS-CSF as directed.
- (2) spare 225 amp breakers have been added to MS-BSF, and (1) 400 amp space (we originally showed (2) 400 amp spaces, but don't have room to keep them both now).
- TVSS units were deleted from the two Main Switch Boards as directed.
- Part 2, #2.10 E - The LCD screens on the switchboards are located on each solid state trip unit, see submittal sheets for additional information.
- Part 2, #2.10 K - The circuit monitor has 8MB of memory, which will exceed the 60 day requirement. The PowerLogic server will maintain more than a year worth of information.
- Part 1, #1.03 B - Housekeeping pads will be provided for all switchboards, but we'd like to eliminate those for the Main Switch Boards (and Future Switch Board) because we have a trench system beneath them. We can do them, but it just makes for a more difficult installation. The support locations and types will be submitted later.
- Part 1, 1.06 A - Short circuit and coordination studies will be done when equipment schedules are completed.
- Part 1, 1.06 C - Certified test reports will be provided when the switchboards are manufactured and shipped.
- Part 1, 1.03 I - All Square D equipment is seismic qualified, seismic restraint calculations will be provided in a separate submittal package.
- Switchboards SDPH-1 and MPH-1 do not have metering provisions, the display units are for the solid state trip units that are needed for the selective coordination of the emergency system.
- Branch panelboards will be submitted later, after circuitry is finished.

Item No.	Qty.	Catalog Number / Details
----------	------	--------------------------

480V SERVICE SWITCHBOARDS

257-00 1 **Designation:** MS-BSF
 SQUARE D CUSTOM QED SWITCHBOARD

System Voltage: 480Y/277V 3Ph 4W 60Hz
 Source Description - Single Main
 System Ampacity - 4000A
 Bussing - Aluminum Plated w/Tin and Copper Plated w/Silver
 Neutral Bus - 100%
 Max Available Fault Current (RMS) - 65kA
 Enclosure - Type 1
 Accessibility: Front Only
 Transparent Ready - TRE1 (5 Web pages of Real Time Data)
 100 Base T Copper Hub System

Dimensions

4 - 42" Wide Section(s)
 4 - 48" Deep Enclosure(s)
 Dimensions: 168.00" W X 48" D X 91.5" H
 Approximate Weight: 7700

Incoming Requirements

Suitable for Use As Service Entrance
 Entry Point: Right of Lineup, Through the Bottom
 Connection Type: Cable
 Circuit Monitor - CM3350 w/ Ethernet Communications Card

Mains

1 - 4000AF/4000AT 100% 3 Pole Stored Energy, Drawout Mounted Circuit: Type NW
 Power Trip Unit, Long Time, Short Time, Instantaneous, Ground Fault
 Circuit Breaker Modbus Communications Wired

Feeders

1 - 1200AS/1200AT 480V 100% Rated 65 kA 3 Pole: Type RJ
 Power Trip Unit, Long Time, Short Time, Instantaneous, Ground Fault
 Circuit Breaker Modbus Communications Wired

1 - 800AS/800AT 480V 80% Rated 65 kA 3 Pole: Type PJ
 Power Trip Unit, Long Time, Short Time, Instantaneous
 Circuit Breaker Modbus Communications Wired

1 - 600AS/600AT 480V 80% Rated 65 kA 3 Pole: Type PJ
 Power Trip Unit, Long Time, Short Time, Instantaneous
 Circuit Breaker Modbus Communications Wired

6 - 400AS/400AT 480V 80% Rated 65 kA 3 Pole: Type PJ
 Power Trip Unit, Long Time, Short Time, Instantaneous
 Circuit Breaker Modbus Communications Wired

2 - 250AS/225AT 480V 80% Rated 65 kA 3 Pole: Type PJ
 Power Trip Unit, Long Time, Short Time, Instantaneous
 Circuit Breaker Modbus Communications Wired

2 - 250AS/200AT 480V 80% Rated 65 kA 3 Pole: Type PJ
 Power Trip Unit, Long Time, Short Time, Instantaneous
 Circuit Breaker Modbus Communications Wired

2 - 250AS/100AT 480V 80% Rated 65 kA 3 Pole: Type PJ
 Power Trip Unit, Long Time, Short Time, Instantaneous
 Circuit Breaker Modbus Communications Wired

2 - 400A Prepared Space: Type PJ

Item No.	Qty.	Catalog Number / Details
272-00	1	<p>Designation: MS-CSF SQUARE D CUSTOM QED SWITCHBOARD</p> <hr/> <p>System Voltage: 480Y/277V 3Ph 4W 60Hz Source Description - Single Main System Ampacity - 4000A Bussing - Aluminum Plated w/Tin and Copper Plated w/Silver Neutral Bus - 100% Max Available Fault Current (RMS) - 65kA Enclosure - Type 1 Accessibility: Front Only Transparent Ready - TRE1 (5 Web pages of Real Time Data) 100 Base T Copper Hub System</p> <p>Dimensions</p> <hr/> <p>4 - 42" Wide Section(s) 4 - 48" Deep Enclosure(s) Dimensions: 168.00" W X 48" D X 91.5" H Approximate Weight: 7780</p> <p>Incoming Requirements</p> <hr/> <p>Suitable for Use As Service Entrance Entry Point: Left of Lineup, Through the Bottom Connection Type: Cable Circuit Monitor - CM3350 w/ Ethernet Communications Card</p> <p>Mains</p> <hr/> <p>1 - 4000AF/4000AT 100% 3 Pole Stored Energy, Drawout Mounted: Type NW Power Trip Unit, Long Time, Short Time, Instantaneous, Ground Fault Circuit Breaker Modbus Communications Wired</p> <p>Feeders</p> <hr/> <p>2 - 1200AS/1200AT 480V 100% Rated 65 kA 3 Pole: Type RJ Power Trip Unit, Long Time, Short Time, Instantaneous, Ground Fault Circuit Breaker Modbus Communications Wired</p> <p>2 - 800AS/800AT 480V 80% Rated 65 kA 3 Pole: Type PJ Power Trip Unit, Long Time, Short Time, Instantaneous Circuit Breaker Modbus Communications Wired</p> <p>8 - 400AS/400AT 480V 80% Rated 65 kA 3 Pole: Type PJ Power Trip Unit, Long Time, Short Time, Instantaneous Circuit Breaker Modbus Communications Wired</p> <p>5 - 250AS/225AT 480V 80% Rated 65 kA 3 Pole: Type PJ Power Trip Unit, Long Time, Short Time, Instantaneous Circuit Breaker Modbus Communications Wired</p> <p>2 - 250AS/100AT 480V 80% Rated 65 kA 3 Pole: Type PJ Power Trip Unit, Long Time, Short Time, Instantaneous Circuit Breaker Modbus Communications Wired</p>

REV	DESCRIPTION	BY	DATE				
-	-	-	-	-	-	-	-

T-bus
19.5 in

T-bus
19.5 in

T-bus
19.5 in

T-bus
36.5 in

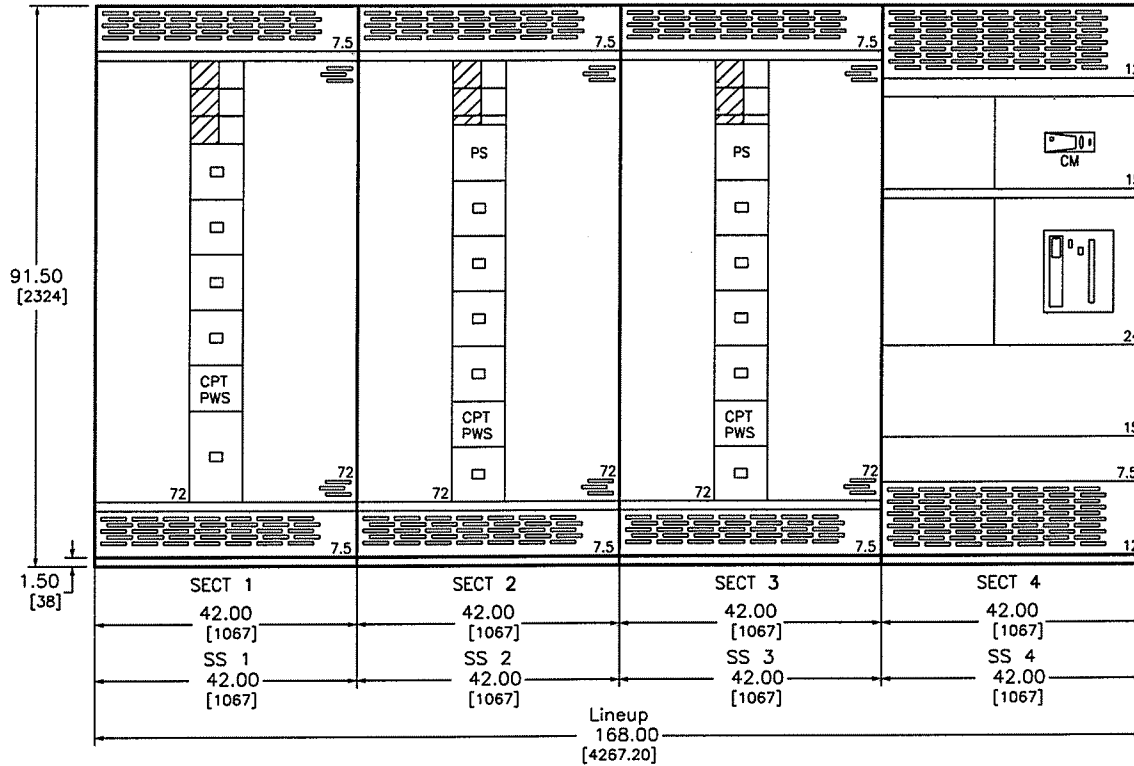

ENGLISH DIMENSIONS: INCHES

JOB NAME:	BATTELLE BUILDINGS	EQUIPMENT DESIGNATION:	MS-BSF
JOB LOCATION:	RICHLAND WA	EQUIPMENT TYPE:	QED Switchboard
DRAWN BY:	(QZC)	DRAWING TYPE:	ELEVATION VIEW
ENGR:			SQUARE D Schneider Electric
DATE:	August 21 2008		
DRAWING STATUS:	QUOTE	DWG#	F23157551-01

REV	DESCRIPTION	BY	DATE						
---	---	---	---	---	---	---	---	---	---

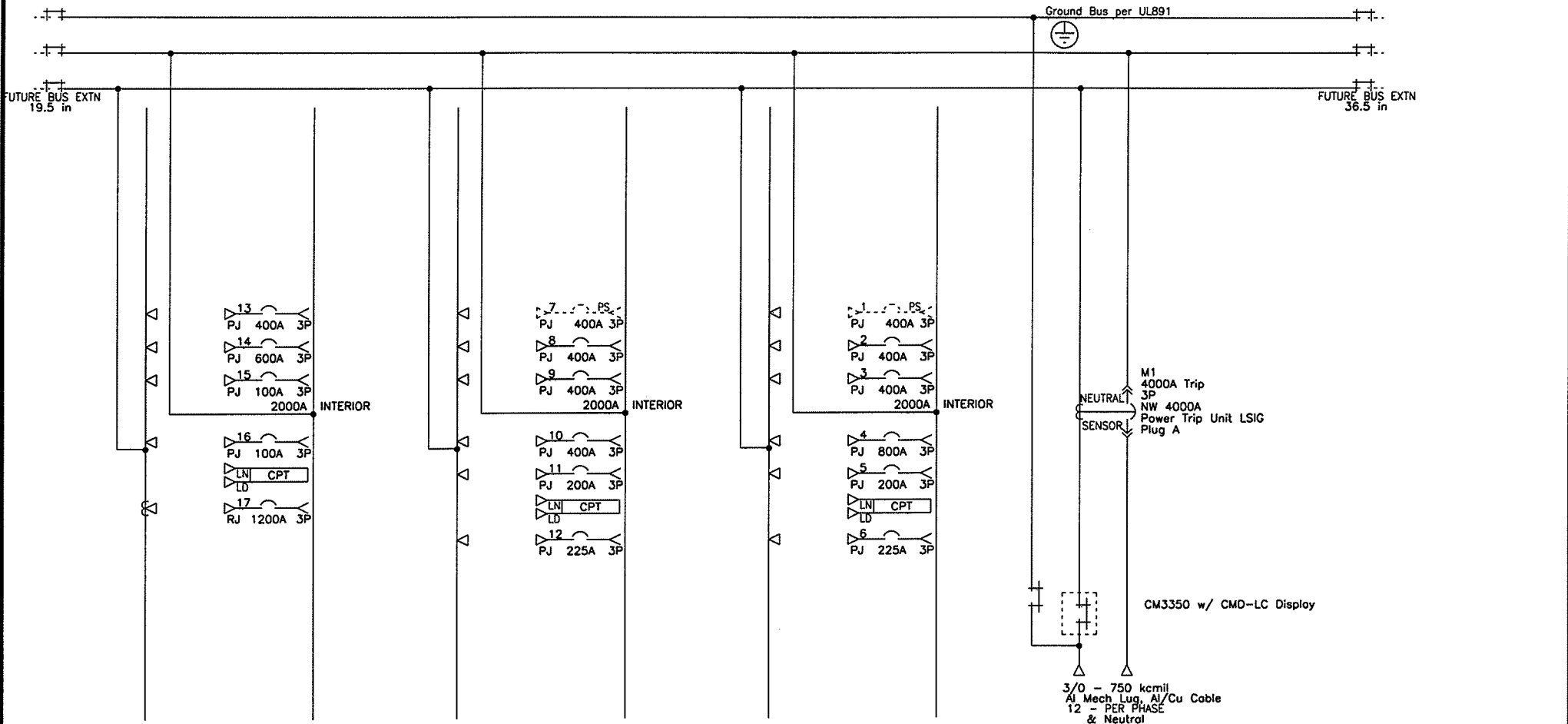

SECTION 1

SECTION 2

SECTION 3

SECTION 4

JOB NAME:	BATTELLE BUILDINGS	EQUIPMENT DESIGNATION:	MS-BSF
JOB LOCATION:	RICHLAND WA	EQUIPMENT TYPE:	OED Switchboard
DRAWN BY:	(Q2C)	DRAWING TYPE:	ONE LINE
ENGR:			
DATE:	August 21 2008		
DRAWING STATUS:	QUOTE	DWG#	023157551-01

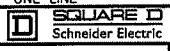

REV	DESCRIPTION	BY	DATE						
---	---	---	---	---	---	---	---	---	---

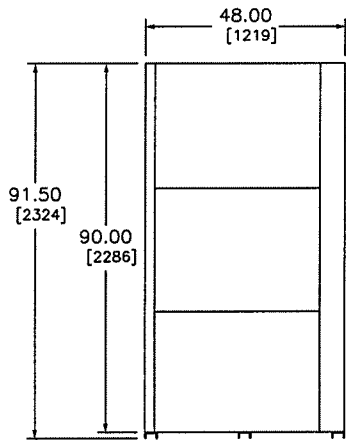

LEFT SIDE VIEW

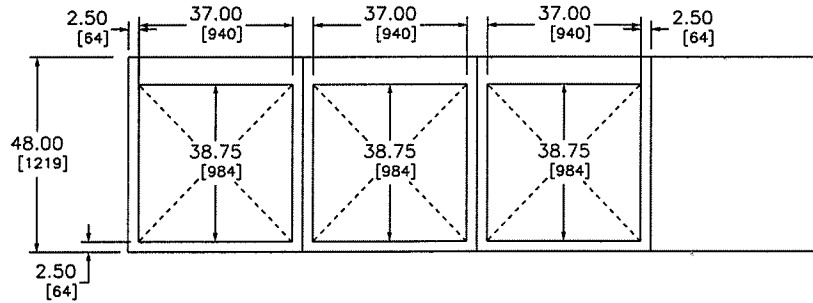

TOP VIEW - FRONT

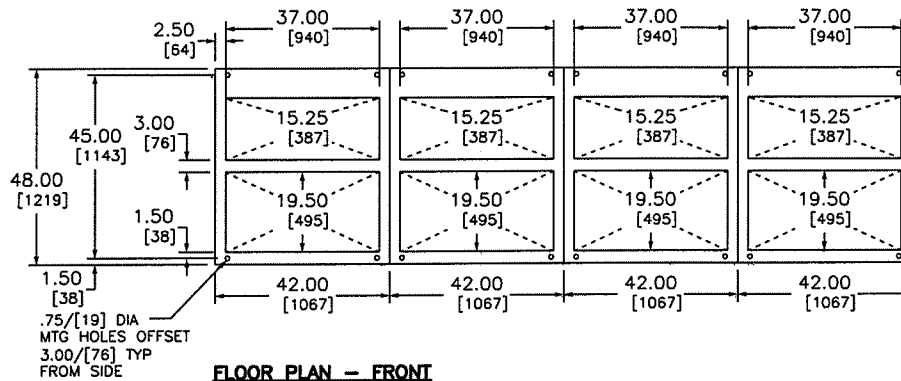

FLOOR PLAN - FRONT

ENGLISH DIMENSIONS: INCHES

JOB NAME:	BATTELLE BUILDINGS	EQUIPMENT DESIGNATION:	MS-BSF
JOB LOCATION:	RICHLAND WA	EQUIPMENT TYPE:	OED Switchboard
DRAWN BY:	(Q2C)	DRAWING TYPE:	SIDE, TOP VIEW & FLOOR PLAN
ENGR:			SQUARE
DATE:	August 21 2008		Schneider Electric
DRAWING STATUS:	QUOTE	DWG#	F23157551-01

REV	DESCRIPTION	BY	DATE						
-	----	--	---/---/---	-	----	--	---/---/---	-	----

SWITCHBOARD GENERAL NOTES

PRODUCT DESCRIPTION & RATINGS

Power System Data

480Y/277V 3Ph 4W 60Hz / 3 Phase Wye
 Solidly Grounded
 System Short Circuit Current Rating: 65kA RMS
 Incoming Section 4 Cable Through the Bottom

Bus System Data

4000A Tin/Aluminum & Silver/Copper Main Bus
 (8) .25x2.00 IN/6x51 mm Cu Bus Bar Per Phase/Neutral
 (1) .25x1.75 IN/6x44 mm Cu Ground Bus

Enclosure Data

Type 1 Free Standing
 Exterior Paint Color: ANSI 49
 Front Accessibility Only Required
 Handling: Rollers
 Equipment Nameplate: White Surface/Black Letters
 Device Nameplate: White Surface / Black Letters

Estimated Shipping Weight

Shipping Split 1 2035 lbs / 923 kgs
 Shipping Split 2 2075 lbs / 941 kgs
 Shipping Split 3 2075 lbs / 941 kgs
 Shipping Split 4 1515 lbs / 687 kgs
 Complete Lineup 7700 lbs / 3493 kgs

Code Standards

U.L. Deadfront and suitable for use as Service Entrance
 when not more than six (6) disconnecting means are provided.

Rating Nameplates

ST1- Deadfront- Section Bus 2000A
 ST2- Deadfront- Section Bus 2000A
 ST3- Deadfront- Section Bus 2000A
 ST4- Service Entrance - Section Bus 4000A

PRODUCT INFORMATION

Wiring

All wiring to be Machine Tool Wire type

Instruction Bulletins

Reference 80043-055 For Handling, Installation,
 Anchoring, Inspection And Maintenance Information

PRODUCT ACCESSORIES/OPTIONS

Transparent Ready Equipment - TRE 1
 Web Enabled & Factory Configured for Ethernet
 5 Web Pages Real Time Data
 Customer Ethernet Network - 10/100Mb Copper

JOB NAME:	BATTELLE BUILDINGS	EQUIPMENT DESIGNATION:	MS-BSF
JOB LOCATION:	RICHLAND WA	EQUIPMENT TYPE:	OED Switchboard
DRAWN BY:	(QZC)	DRAWING TYPE:	GENERAL NOTES
ENGR:			SCHNEIDER ELECTRIC
DATE:	August 21 2008		Schneider Electric
DRAWING STATUS:	QUOTE	DWG# F23157551-01	PG 3 OF 3 REV -

REV	DESCRIPTION	BY	DATE										
-	-	-	-	-	-	-	-	-	-	-	-	-	-

POWER STYLE QED-2 SWITCHBOARD

SECT NO	CKT NO	GMD HEIGHT	DEVICE/FRAME RATING	TRIP AMP	FUSE/TRIP	#P	DESIGNATION	N/P	LUG INFORMATION				ACCESSORIES
									QTY	PHASE WIRE RANGE	QTY	NEUT. WIRE RANGE	
1	13	9 in	PJ 400A Plug A	400A	P-LSI	3P	TK-1A1	Yes	3	3/0 - 500 kcmil	1	250 - 600 kcmil	COM
1	14	9 in	PJ 600A Plug A	600A	P-LSI	3P	MPH-RB	Yes	3	3/0 - 500 kcmil	2	250 - 600 kcmil	COM
1	15	9 in	PJ 250A Plug A	100A	P-LSI	3P	ELEVATOR-2	Yes	-	3/0 - 500 kcmil	-	#6 - 350 kcmil	COM
1	16	9 in	PJ 250A Plug A	100A	P-LSI	3P	ELEVATOR-1	Yes	-	3/0 - 500 kcmil	-	#6 - 350 kcmil	COM
1	-	7.5 in	I/L CPT w 24vdc ps	-	-	-	-	-	-	-	-	-	CPT, PS
1	17	15 in	RJ1200A Plug A 100%	1200A	LSIG	3P	CHILLER CH-1	Yes	4	3/0 - 600kcmil	4	3/0 - 500kcmil	GF,COM
2	7	9 in	PJ 400A (PS)	(400A)	(LSI)	3P	SPACE	Yes	3	3/0 - 500 kcmil	1	250 - 600 kcmil	
2	8	9 in	PJ 400A Plug A	400A	P-LSI	3P	TK-1A2	Yes	3	3/0 - 500 kcmil	1	250 - 600 kcmil	COM
2	9	9 in	PJ 400A Plug A	400A	P-LSI	3P	LPH-2B	Yes	3	3/0 - 500 kcmil	1	250 - 600 kcmil	COM
2	10	9 in	PJ 400A Plug A	400A	P-LSI	3P	LHP-1B	Yes	3	3/0 - 500 kcmil	1	250 - 600 kcmil	COM
2	11	9 in	PJ 250A Plug A	200A	P-LSI	3P	LPH-1A	Yes	-	3/0 - 500 kcmil	-	#6 - 350 kcmil	COM
2	-	7.5 in	I/L CPT w 24vdc ps	-	-	-	-	-	-	-	-	-	CPT, PS
2	12	9 in	PJ 250A Plug A	225A	P-LSI	3P	SPARE	Yes	-	3/0 - 500 kcmil	-	#6 - 350 kcmil	COM
3	1	9 in	PJ 400A (PS)	(400A)	(LSI)	3P	SPACE	Yes	3	3/0 - 500 kcmil	1	250 - 600 kcmil	
3	2	9 in	PJ 400A Plug A	400A	P-LSI	3P	TK-2A2	Yes	3	3/0 - 500 kcmil	1	250 - 600 kcmil	COM
3	3	9 in	PJ 400A Plug A	400A	P-LSI	3P	TK-2A1	Yes	3	3/0 - 500 kcmil	1	250 - 600 kcmil	COM
3	4	9 in	PJ 800A Plug A	800A	P-LSI	3P	NDPH-1	Yes	3	3/0 - 500 kcmil	3	250 - 600 kcmil	COM
3	5	9 in	PJ 250A Plug A	200A	P-LSI	3P	LPH-2A	Yes	-	3/0 - 500 kcmil	-	#6 - 350 kcmil	COM
3	-	7.5 in	I/L CPT w 24vdc ps	-	-	-	-	-	-	-	-	-	CPT, PS
3	6	9 in	PJ 250A Plug A	225A	P-LSI	3P	SPARE	Yes	-	3/0 - 500 kcmil	-	#6 - 350 kcmil	COM
4	-	-	Circuit Monitor	-	-	-	-	-	-	-	-	-	CM
4	M1	-	NW 4000A Plug A	4000A	P-LSIG	3P	MAIN	Yes	12	3/0 - 750 kcmil	12	3/0 - 750 kcmil	OC,OF4,CCKK,CCPS,GF,COM

LEGEND	
CCKK	Cradle Cell Key Kit
CCPS	Cradle Cell Position Switch
COM	Communications
GF	Ground Fault
OC	Over Current Trip Switch
OF4	4 Form C Breaker Aux Contacts

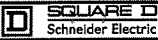
JOB NAME:	BATTELLE BUILDINGS	EQUIPMENT DESIGNATION:	MS-BSF
JOB LOCATION:	RICHLAND WA	EQUIPMENT TYPE:	QED Switchboard
DRAWN BY:	(Q2C)	DRAWING TYPE:	SCHEDULE
ENGR:			
DATE:	August 21 2008		
DRAWING STATUS:	QUOTE	DWG#	023157551-01

REV	DESCRIPTION	BY	DATE						
-	-	-	-	-	-	-	-	-	-

T-bus
36.5 in

T-bus
19.5 in

T-bus
19.5 in

T-bus
19.5 in

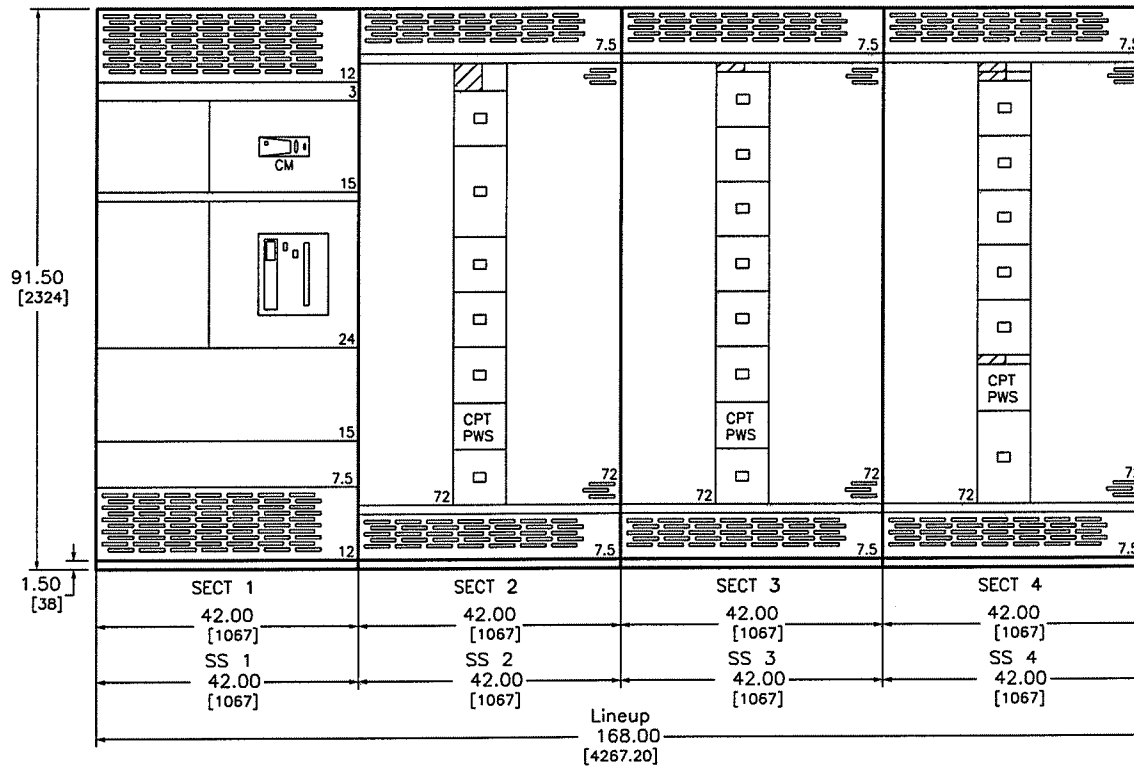

ENGLISH DIMENSIONS: INCHES

JOB NAME: BATTELLE BUILDINGS	EQUIPMENT DESIGNATION: MS-CSF
JOB LOCATION: RICHLAND WA	EQUIPMENT TYPE: OED Switchboard
DRAWN BY: (QZC)	DRAWING TYPE: ELEVATION VIEW
ENGR:	 Schneider Electric
DATE: August 21 2008	
DRAWING STATUS: QUOTE	DWG# F23157551-01

REV	DESCRIPTION	BY	DATE						
-	-	-	-	-	-	-	-	-	-

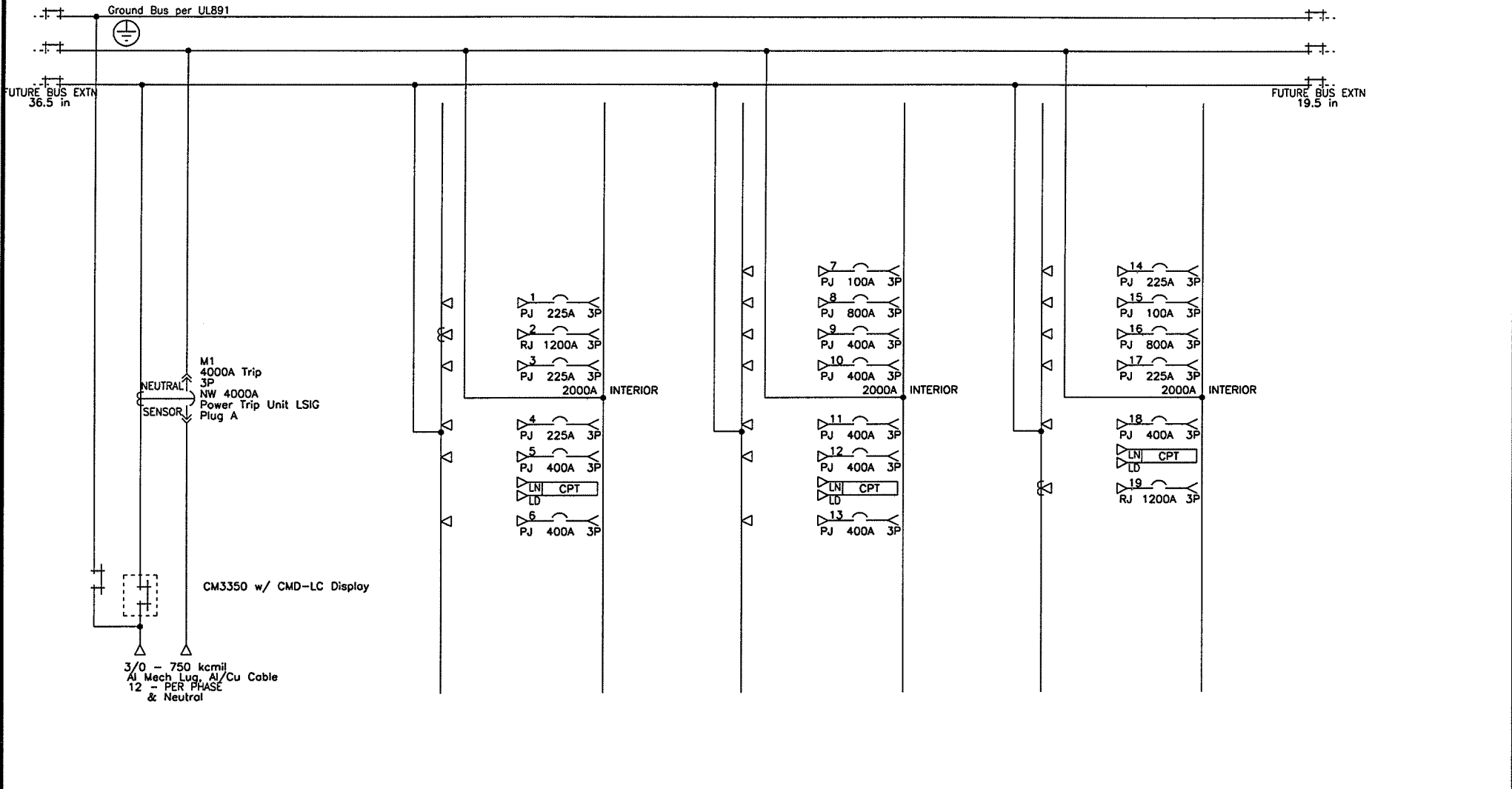

SECTION 1

SECTION 2

SECTION 3

SECTION 4

JOB NAME:	BATTELLE BUILDINGS	EQUIPMENT DESIGNATION:	MS-CSF
JOB LOCATION:	RICHLAND WA	EQUIPMENT TYPE:	OED Switchboard
DRAWN BY:	(OZC)	DRAWING TYPE:	ONE LINE
ENGR:			SQUARE D Schneider Electric
DATE:	August 21 2008		
DRAWING STATUS:	QUOTE	DWG#	023157551-01

REV	DESCRIPTION	BY	DATE						

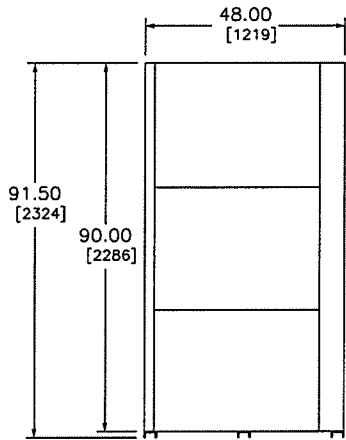

LEFT SIDE VIEW

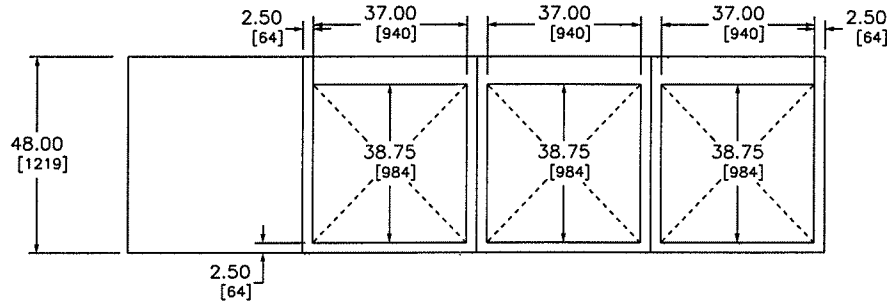

TOP VIEW - FRONT

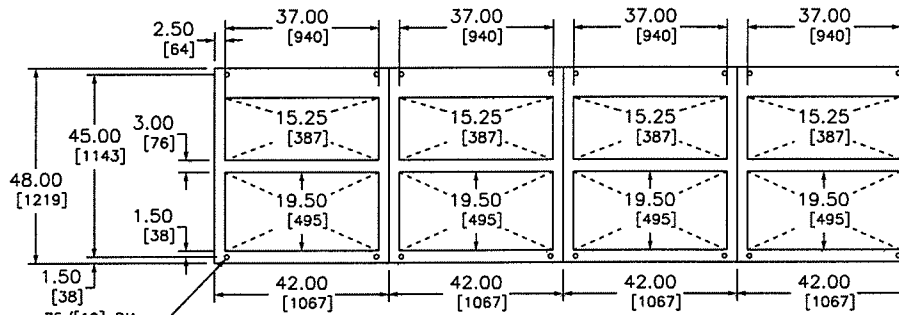

1.50 [38]
 .75/[19] DIA
 MTG HOLES OFFSET
 3.00/[76] TYP
 FROM SIDE

FLOOR PLAN - FRONT

ENGLISH DIMENSIONS: INCHES

JOB NAME:	BATTELLE BUILDINGS	EQUIPMENT DESIGNATION:	MS-CSF
JOB LOCATION:	RICHLAND WA	EQUIPMENT TYPE:	OED Switchboard
DRAWN BY:	(Q2C)	DRAWING TYPE:	SIDE, TOP VIEW & FLOOR PLAN
ENGR:			SQUARE D
DATE:	August 21 2008		Schneider Electric
DRAWING STATUS:	QUOTE	DWG# F23157551-01	PG 2 OF 3 REV -

REV	DESCRIPTION	BY	DATE						
-	----	---	---/---/---	-	----	---	---/---/---	-	----

SWITCHBOARD GENERAL NOTES

PRODUCT DESCRIPTION & RATINGS

Power System Data

480Y/277V 3Ph 4W 60Hz / 3 Phase Wye
Solidly Grounded
System Short Circuit Current Rating: 65ka RMS
Incoming Section 1 Cable Through the Bottom

Bus System Data

4000A Tin/Aluminum & Silver/Copper Main Bus
(8) .25x2.00 IN/6x51 mm Cu Bus Bar Per Phase/Neutral
(1) .25x1.75 IN/6x44 mm Cu Ground Bus

Enclosure Data

Type 1 Free Standing
Exterior Paint Color: ANSI 49
Front Accessibility Only Required
Handling: Rollers
Equipment Nameplate: White Surface/Black Letters
Device Nameplate: White Surface / Black Letters

Estimated Shipping Weight

Shipping Split 1 1515 lbs / 687 kgs
Shipping Split 2 2075 lbs / 941 kgs
Shipping Split 3 2115 lbs / 959 kgs
Shipping Split 4 2075 lbs / 941 kgs
Complete Lineup 7780 lbs / 3529 kgs

Code Standards

U.L. Deadfront and suitable for use as Service Entrance
when not more than six (6) disconnecting means are provided.

Rating Nameplates

ST1- Service Entrance - Section Bus 4000A
ST2- Deadfront- Section Bus 2000A
ST3- Deadfront- Section Bus 2000A
ST4- Deadfront- Section Bus 2000A

PRODUCT INFORMATION

Wiring

All wiring to be Machine Tool Wire type

Instruction Bulletin

Reference 80043-055 For Handling, Installation,
Anchoring, Inspection And Maintenance Information

PRODUCT ACCESSORIES/OPTIONS

Transparent Ready Equipment - TRE 1
Web Enabled & Factory Configured for Ethernet
5 Web Pages Real Time Data
Customer Ethernet Network - 10/100Mb Copper

JOB NAME:	BATTELLE BUILDINGS	EQUIPMENT DESIGNATION:	MS-CSF
JOB LOCATION:	RICHLAND WA	EQUIPMENT TYPE:	OED Switchboard
DRAWN BY:	(OZC)	DRAWING TYPE:	GENERAL NOTES
ENGR:			Schneider Electric
DATE:	August 21 2008		
DRAWING STATUS:	QUOTE	DWG# F23157551-01	PG 3 OF 3 REV -

REV	DESCRIPTION	BY	DATE								
-	-	-	-	-	-	-	-	-	-	-	-

POWER STYLE QED-2 SWITCHBOARD

SECT NO	CKT NO	GMD HEIGHT	DEVICE/FRAME RATING	TRIP AMP	FUSE/TRIP	#P	DESIGNATION	N/P	LUG INFORMATION				ACCESSORIES
									QTY	PHASE WIRE RANGE	QTY	NEUT. WIRE RANGE	
1	-	-	Circuit Monitor	-	-	-	-	-	-	-	-	CM	
1	M1	-	NW 4000A Plug A	4000A	P-LSIG	3P	MAIN	Yes	12	3/0 - 750 kcmil	12	3/0 - 750 kcmil	OC,OF4,CCKK,CCPS,GF,COM
2	1	9 in	PJ 250A Plug A	225A	P-LSI	3P	SPARE	Yes	-	3/0 - 500 kcmil	-	#6 - 350 kcmil	COM
2	2	15 in	RJ1200A Plug A 100%	1200A	LSIG	3P	DPH-1A1	Yes	4	3/0 - 600kcmil	4	3/0 - 500kcmil	GF,COM
2	3	9 in	PJ 250A Plug A	225A	P-LSI	3P	LPH-2A1	Yes	-	3/0 - 500 kcmil	-	#6 - 350 kcmil	COM
2	4	9 in	PJ 250A Plug A	225A	P-LSI	3P	LPH-1A1	Yes	-	3/0 - 500 kcmil	-	#6 - 350 kcmil	COM
2	5	9 in	PJ 400A Plug A	400A	P-LSI	3P	TK-RE-2A1	Yes	3	3/0 - 500 kcmil	1	250 - 600 kcmil	COM
2	-	7.5 in	I/L CPT w 24vdc ps	-	-	-	-	-	-	-	-	-	CPT, PS
2	6	9 in	PJ 400A Plug A	400A	P-LSI	3P	TK-RE-1A1	Yes	3	3/0 - 500 kcmil	1	250 - 600 kcmil	COM
3	7	9 in	PJ 250A Plug A	100A	P-LSI	3P	ELEVATOR-3	Yes	-	3/0 - 500 kcmil	-	#6 - 350 kcmil	COM
3	8	9 in	PJ 800A Plug A	800A	P-LSI	3P	DPH-2A1	Yes	3	3/0 - 500 kcmil	3	250 - 600 kcmil	COM
3	9	9 in	PJ 400A Plug A	400A	P-LSI	3P	LPH-2M1	Yes	3	3/0 - 500 kcmil	1	250 - 600 kcmil	COM
3	10	9 in	PJ 400A Plug A	400A	P-LSI	3P	LPH-1M1	Yes	3	3/0 - 500 kcmil	1	250 - 600 kcmil	COM
3	11	9 in	PJ 400A Plug A	400A	P-LSI	3P	SPARE	Yes	3	3/0 - 500 kcmil	1	250 - 600 kcmil	COM
3	12	9 in	PJ 400A Plug A	400A	P-LSI	3P	TK-RW-4A1	Yes	3	3/0 - 500 kcmil	1	250 - 600 kcmil	COM
3	-	7.5 in	I/L CPT w 24vdc ps	-	-	-	-	-	-	-	-	-	CPT, PS
3	13	9 in	PJ 400A Plug A	400A	P-LSI	3P	TK-RW-3A1	Yes	3	3/0 - 500 kcmil	1	250 - 600 kcmil	COM
4	14	9 in	PJ 250A Plug A	225A	P-LSI	3P	SPARE	Yes	-	3/0 - 500 kcmil	-	#6 - 350 kcmil	COM
4	15	9 in	PJ 250A Plug A	100A	P-LSI	3P	T-CP	Yes	-	3/0 - 500 kcmil	-	#6 - 350 kcmil	COM
4	16	9 in	PJ 800A Plug A	800A	P-LSI	3P	MPH-1	Yes	3	3/0 - 500 kcmil	3	250 - 600 kcmil	COM
4	17	9 in	PJ 250A Plug A	225A	P-LSI	3P	DPH-1A2	Yes	-	3/0 - 500 kcmil	-	#6 - 350 kcmil	COM
4	18	9 in	PJ 400A Plug A	400A	P-LSI	3P	MPH-R1	Yes	3	3/0 - 500 kcmil	1	250 - 600 kcmil	COM
4	-	7.5 in	I/L CPT w 24vdc ps	-	-	-	-	-	-	-	-	-	CPT, PS
4	19	15 in	RJ1200A Plug A 100%	1200A	LSIG	3P	CHILLER CH-1	Yes	4	3/0 - 600kcmil	4	3/0 - 500kcmil	GF,COM

LEGEND	
CCKK	Cradle Cell Key Kit
CCPS	Cradle Cell Position Switch
COM	Communications
GF	Ground Fault
OC	Over Current Trip Switch
OF4	4 Form C Breaker Aux Contacts

JOB NAME:	BATTELLE BUILDINGS	EQUIPMENT DESIGNATION:	MS-CSF
JOB LOCATION:	RICHLAND WA	EQUIPMENT TYPE:	QED Switchboard
DRAWN BY:	(Q2C)	DRAWING TYPE:	SCHEDULE
ENGR:			
DATE:	August 21 2008		
DRAWING STATUS:	QUOTE	DWG# 023157551-01	PG 2 OF 2 REV -

POWERLOGIC® Series 3000 Circuit Monitor

*Measure And Control Energy Costs,
And Minimize Unplanned Downtime*

Looking for a way to measure and control energy costs, and minimize unplanned downtime? Square D, the leader in power management technology, has the answer with the new POWERLOGIC® Series 3000 Circuit Monitor (CM3000). Designed for industrial, large commercial, and OEM users, the new CM3000 is the ideal monitoring device for electrical mains, and branch feeders, as well as OEM applications, such as computer power. Our new POWERLOGIC Series 3000 Circuit Monitor gives you instant access to real time web pages without installing or learning special software.

The Most Powerful Mid-Range Circuit Monitor Available

The CM3000 features the same technology as the most powerful permanently mounted circuit monitor available, the POWERLOGIC CM4000. Using a standard web browser, the highly accurate CM3000 can serve up instantaneous readings, predictive forecasting trends, energy usage cost, power quality and disturbance analysis, or even customized web pages. And, you can web-access summary data transparently from other devices connected downstream, giving you the information necessary to make proactive business and engineering decisions. With extensive onboard memory, the CM3000 gives you the ability to drill down to the detail necessary to facilitate troubleshooting, identify trends, and maintain the control you need over your electrical system.

Features and Benefits

- **Most User Friendly Web-Enabled Circuit Monitor** — Using an Ethernet Communication Card (ECC), the CM3000 features web-enabled technology built right into the circuit monitor itself, making it easy to access information from any PC with a standard Web browser, such as Internet Explorer.
- **Exclusive Built-In Forecasting** — In addition to providing historical data through trending analysis, the CM3000 circuit monitor also provides exclusive forecasting information of electrical parameters, which allows the customers to look into the future and make better decisions about impending usage, and helps you measure and control energy costs.
- **Eliminates Blind Spots in Data Collection** — The CM3000 samples continuously at 128 times per cycle, leaving no blind spots in data collection. With faster processing power than other circuit monitors in its class, the CM3000 provides simultaneous, accurate collection of real-time data and, onboard data logs, waveforms and disturbances. Consequently, the CM3000 gives you the most reliable information on which to base power management decisions that can help you minimize unplanned downtime.
- **Faster and Less Expensive to Install** — The CM3000 can connect directly with up to 600V metering inputs as opposed to traditional 120V. (Eliminates the need for potential transformers [PTs], up to 600 V, to step line voltage down to metering levels and eliminates the extra wiring associated with PTs.)
- **Small Footprint Saves Space** — the POWERLOGIC CM3000 can be mounted virtually anywhere inside the electrical equipment, and doesn't require a separate metering compartment. Built-in tabs for DIN rail mounting are especially useful for OEM and retrofit applications because they make the CM3000 easier to install.

Models Available:

- CM3350
- CM3250

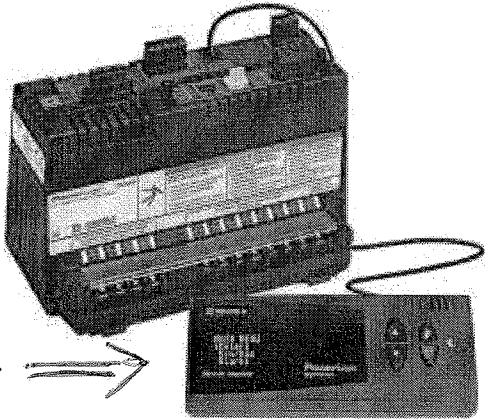

Local circuit monitor
Display: MS-BSF? CSF

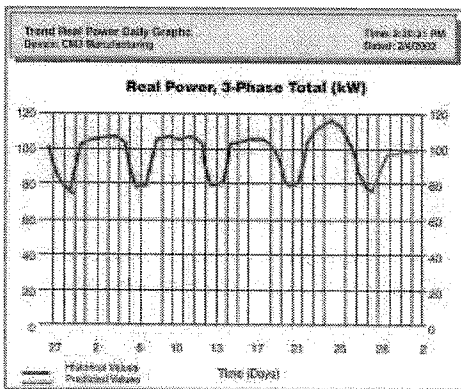

With more processing power than competitive meters, the CM3000 can perform onboard trending and load forecasting up to four days in advance

Merlin Gerin
Modicon
Square D
Telemecanique
Schneider Electric Brands



SQUARE D
Schneider Electric

M-frame, P-frame, R-frame and NS630b–NS3200 Electronic Trip Circuit Breakers

Electronic Trip Systems

Micrologic® 5.0P and 6.0P Trip Units with Power Metering

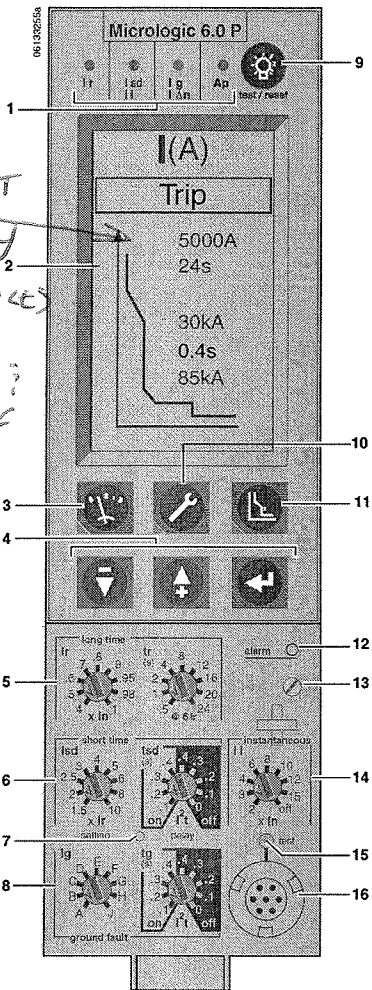

- 1—Indication of tripping cause
- 2—High resolution screen
- 3—Measurement display
- 4—Navigation buttons
- 5—Long-time current setting and tripping delay
- 6—Short-time pickup and tripping delay
- 7—Hole for settings lockout pin
- 8—Ground-fault pickup and tripping delay
- 9—Test lamp and indication reset
- 10—Maintenance indicators
- 11—Protection settings
- 12—Overload signal (LED)
- 13—Long-time rating plug screw
- 14—Instantaneous pickup
- 15—Electronic push-to-trip
- 16—Test connector

Micrologic P trip units provide power metering and extended protection in addition to the adjustable protection functions of the Micrologic A trip unit.

Protection Settings

The adjustable protection functions of the 5.0P and 6.0P trip units are identical to those of Micrologic A trip unit (overloads, short circuits, equipment ground-fault protection; see page 24). These units also feature:

- Fine adjustment
 - Within the range below the rotary switch setting, fine adjustments of pickups/delays in steps of 1 A/s (except for short-time and ground-fault) are possible on the keypad or remotely by the communication network.
- Inverse definite minimum time lag (IDMTL) setting.
 - Coordination with fuse-type or medium-voltage protection systems is optimized by adjusting the long-time delay curve around $6 \times I_r$ axis. This setting ensures better coordination with certain loads.
- Neutral protection
 - On three-pole circuit breakers, neutral protection may be set using the keypad or remotely using the communication network to one of four positions: OFF, $1/2N$ ($1/2 \times I_n$), $1N$ ($1 \times I_n$), or $1.6N$ ($2 \times I_n$).

NOTE: Neutral protection is disabled if long-time curve is set to one of the IDMTL protection settings.

Configuring Alarms and Other Protection Functions

When the cover is closed, the keypad may no longer be used to change the protection settings, but it still provides access to the displays for measurements, histories, indicators, etc. Depending on the thresholds and time delays set, the Micrologic P trip unit monitors current, voltage, power, frequency, and phase sequence. Each threshold overrun may be signalled remotely via the communication network.

Each threshold overrun may be combined with tripping (protection) or an indication carried out by an optional M6C programmable contact (alarm), or both (protection and alarm).

Maintenance Record

The maintenance record can be consulted using the full-function test kit or remotely via the communication network. It can be used as an aid in troubleshooting and to assist scheduling for device maintenance operations. Recorded indications include:

- Highest current measured
- Operation counter (cumulative total and total since last reset)
- Number of test kit connections
- Number of trips in operating mode

Load Shedding and Reconnection Parameters

Load shedding and reconnection parameters can be set according to the power or the current flowing through the circuit breaker. Load shedding is carried out by a remote computer via the communication network or by an M6C programmable contact.

M-frame, P-frame, R-frame and NS630b–NS3200 Electronic Trip Circuit Breakers Electronic Trip Systems

Table 27: Micrologic P Use of External 24 Vdc Power Supply

Function	Without 24 Vdc Power Supply at F1 and F2	With 24 Vdc Power Supply at F1 and F2
Fault Protection for LSIG Functions	Yes	Yes
LED Trip Indication	Yes ¹	Yes
LCD Display and Backlight are Functional	Yes ¹	Yes
Ground-Fault Push-to-Trip Button Works for Testing Ground Fault ²	Yes ¹	Yes
Metering, Monitoring, and History Logs are Functional	Yes ¹	Yes
Communications Between Trip Unit and M2C and M6C Programmable Contact Modules	No	Yes
Operation of M6C Programmable Contact Module	No	Yes, with separate 24 Vdc power supply for the module
Modbus [®] Communications	No	Yes, with separate 24 Vdc power supply for the circuit breaker communication module

¹ If circuit breaker has 100 Vac or more between two phases or phase to neutral and is bottom fed or closed in a top fed application.
² Ground-fault push-to-trip button will also be functional if hand-held test kit or full-function test kit is powering the trip unit.

Tripping and Alarm Histories

The last ten trips and ten alarms are recorded in two separate history files that can be displayed on the screen (sample displays are shown).

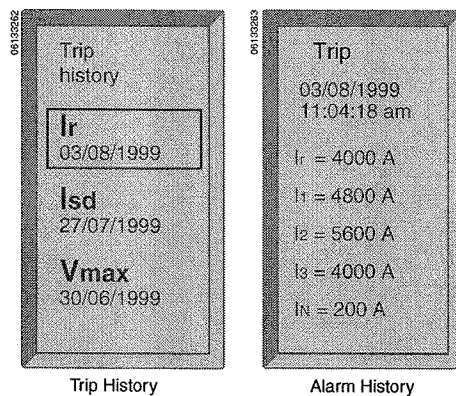

The following information is contained in these files:

Trip History

- Type of fault
- Date and time of fault
- Interrupted current

Alarm History

- Type of alarm
- Date and time of alarm
- Values measured at time of alarm

Metering

The Micrologic P trip unit calculates in real time the electrical values V, A, W, VAR, VA, Wh, VARh, VAh, Hz, power factor and crest factor. It also calculates demand current and power over an adjustable time period.

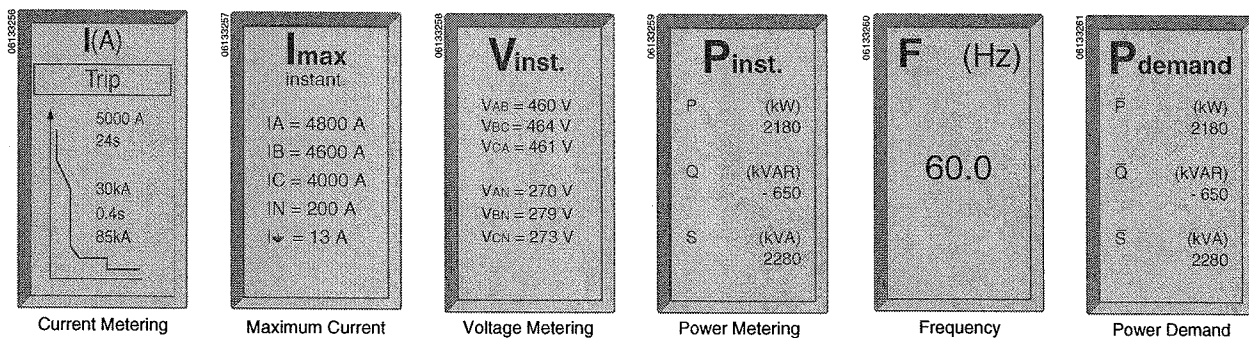

Resubmittal

Section 26 22 13

Transformers

Transformer resubmittal synopsis:

- The following transformers are Harmonic Mitigating type:

T-CP

T-ECP

STK-1A

STK-2A

STK-1C

ET-1B

TK-1B

TK-2B

TK-1A1

TK-2A2

TK-2A1

TK-1A2

TK-RE-1A1

TK-RE-2A1

TK-RW-3A1

TK-RW-4A1

Any not listed here remain as we previously submitted.

Item No.	Qty.	Catalog Number / Details
<u>TRANSFORMERS</u>		
273-00	1	Designation: T-CP EE30T3HF Transformer Dry Type 30kVA 480D208Y120,115C
285-00	1	Designation: T-ECP EE15T3HF Transformer Dry Type 15kVA 480D208Y120,115C
323-00	2	Designation: STK 1A/2A EE225T3HFISNL Transformer Dry Type 225kVA 480D208Y120, K4
324-00	1	Designation: STK-1C EE30T3HFISNL Transformer Dry Type 30kVA 480D208Y120, K4
325-00	1	Designation: ET-1B EE15T3HFISNL Transformer Dry Type 15kVA 480D208Y120, K4
319-00	1	Designation: TK-1B HM112T208NCU HMT TRFMR DRY TYPE 112.5KVA 480D208ZZ120,0D
327-00	1	Designation: TK-2B HM112T255NCU HMT TRFMR DRY TYPE 112.5KVA 480-208120,30D
328-00	2	Designation: TK- 1A1 / 2A2 HM225T255NCU HMT TRFMR DRY TYPE 225KVA 480-208ZZ120,30D
320-00	2	Designation: TK-2A1 / 1A2 HM225T208NCU HMT TRFMR DRY TYPE 225KVA 480D208ZZ120,0DEG
321-00	2	Designation: TK-RE-2A1/ RW-3A1 HM225T255NCU HMT TRFMR DRY TYPE 225KVA 480-208ZZ120,30D
322-00	1	Designation: TK-RW-4A1 HM150T208NCU HMT TRFMR DRY TYPE 150KVA 480D208ZZ120,0DEG
329-00	1	Designation: TK-RE-1A1 HM225T208NCU HMT TRFMR DRY TYPE 225KVA 480D208ZZ120,0DEG

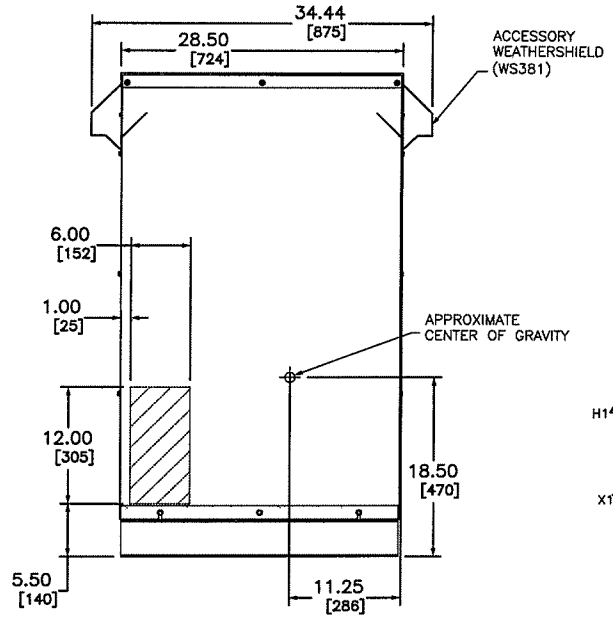
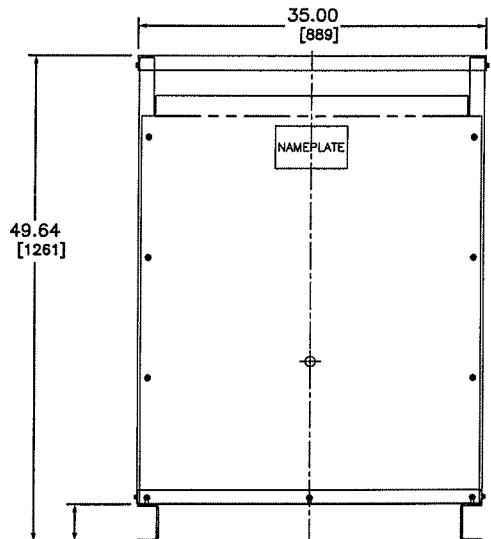

IN EACH PHASE CONNECT TO TAPS	
PRIMARY VOLTS	2-2.5% FCAN 4-2.5% FCBN
504	1
492	2
480	3
468	4
456	5
444	6
432	7

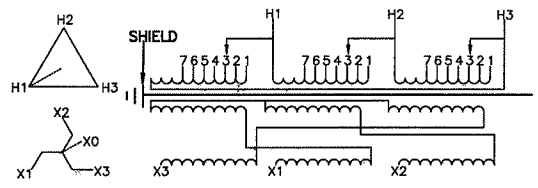
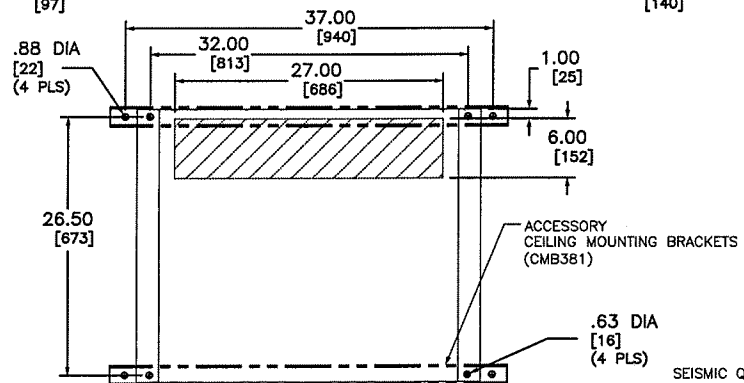

TRANSFORMER SPECIFICATIONS:
 225 KVA 3Ø 60 HZ
 PRIMARY VOLTAGE 480 DELTA
 SECONDARY VOLTAGE 208/120 ZIG ZAG
 150°C RISE ABOVE 40°C AMBIENT
 220°C INSULATION SYSTEM
 COPPER WINDINGS
 APPROXIMATE WEIGHT: 1125 LBS
 GUARANTEED SOUND LEVEL: 55 dB
 EFFICIENCY @35%: 98.5% AVG. CONFORMS
 TO NEMA TP 1 - 2002 AND CSA C802.2

- NOTES:
- 1) cULus LISTED (MEETING UL 1561 AND CSA C22.2)
 - 2) NEMA 2 VENTILATED ENCLOSURE ENCLOSURE RATED FOR NEMA 3R WHEN OPTIONAL WEATHERSHIELD ACCESSORY IS INSTALLED.
 - 3) MINIMUM CLEARANCE OF 3.00 [76] BETWEEN VENT OPENINGS, WALL OR OTHER OBSTRUCTION
 - 4) SHADED AREAS DENOTE CUSTOMER CONDUIT ENTRANCE LOCATIONS, AVAILABLE BOTH SIDES AND BOTTOM

SEISMIC QUALIFICATION:
 TO BE COMPLIANT WITH THE SEISMIC REQUIREMENTS OF ASCE/SEI 7, THIS UNIT HAS BEEN QUALIFIED BY SHAKE TABLE TESTING THROUGH SELF CERTIFICATION TO ICC ES AC156. CONTACT YOUR LOCAL SCHNEIDER ELECTRIC/SQUARE D REPRESENTATIVE FOR RELATED QUESTIONS.

DUAL DIMENSIONS: INCHES
 MILLIMETERS

LOW VOLTAGE HARMONIC MITIGATION DRY-TYPE TRANSFORMER CATALOG NO HM225T208NCU 3 PHASE, 225KVA, CU PRIMARY 480 DELTA ,SECONDARY 208/120 ZIG ZAG	
DWG# 6312-2169 NO.	

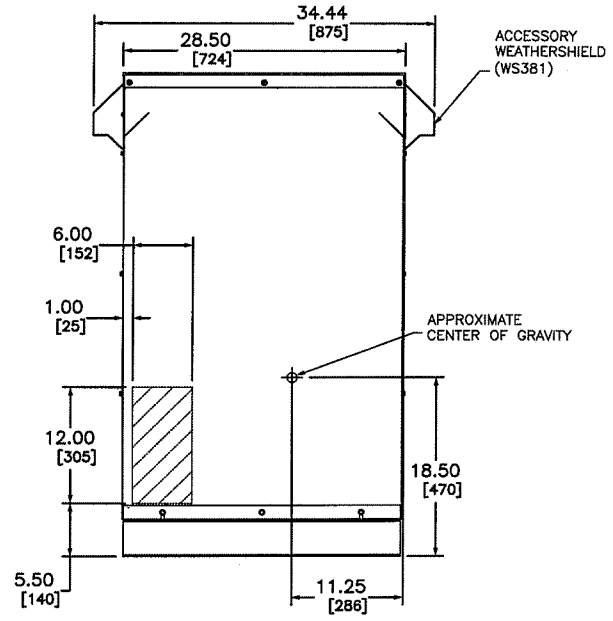
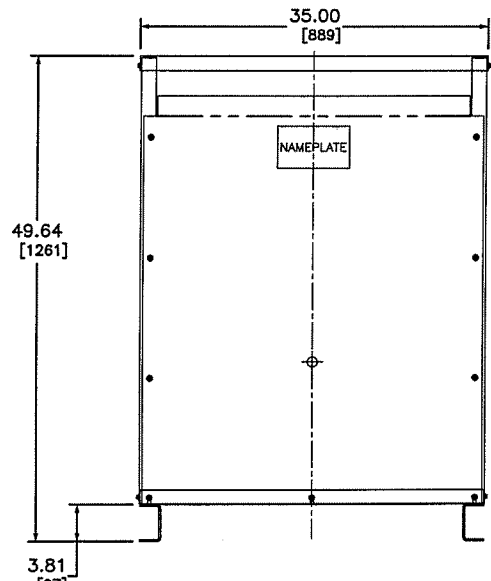

IN EACH PHASE CONNECT TO TAPS	
PRIMARY VOLTS	1-5 %FCAN 2-5 %FCBN
504	1
480	2
456	3
432	4

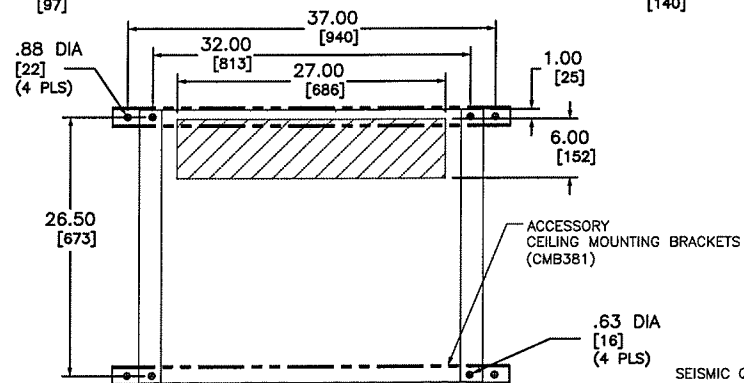
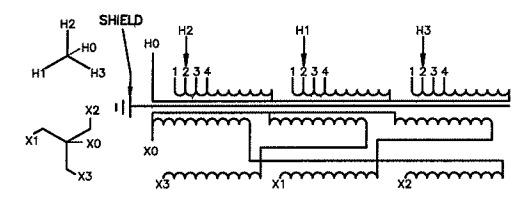

TRANSFORMER SPECIFICATIONS:
 225 KVA 3Ø 60 HZ
 PRIMARY VOLTAGE 480 WYE
 SECONDARY VOLTAGE 208/120 ZIG ZAG
 150 °C RISE ABOVE 40°C AMBIENT
 220 °C INSULATION SYSTEM
 COPPER WINDINGS
 APPROXIMATE WEIGHT: 1125 LBS
 GUARANTEED SOUND LEVEL: 55 dB
 EFFICIENCY @35%: 98.5% AVG. CONFORMS
 TO NEMA TP 1 - 2002 AND CSA C802.2

- NOTES:
 1) cULus LISTED (MEETING UL 1561 AND CSA C22.2)
 2) NEMA 2 VENTILATED ENCLOSURE ENCLOSURE RATED FOR NEMA 3R WHEN OPTIONAL WEATHERSHIELD ACCESSORY IS INSTALLED.
 3) MINIMUM CLEARANCE OF 3.00[76] BETWEEN VENT OPENINGS, WALL OR OTHER OBSTRUCTION
 4) SHADED AREAS DENOTE CUSTOMER CONDUIT ENTRANCE LOCATIONS, AVAILABLE BOTH SIDES AND BOTTOM

SEISMIC QUALIFICATION:
 TO BE COMPLIANT WITH THE SEISMIC REQUIREMENTS OF ASCE/SEI 7, THIS UNIT HAS BEEN QUALIFIED BY SHAKE TABLE TESTING THROUGH SELF CERTIFICATION TO ICC ES AC156. CONTACT YOUR LOCAL SCHNEIDER ELECTRIC/SQUARE D REPRESENTATIVE FOR RELATED QUESTIONS.

DUAL DIMENSIONS: INCHES
 MILLIMETERS

LOW VOLTAGE HARMONIC MITIGATION DRY-TYPE TRANSFORMER CATALOG NO HM225T255NCU 3 PHASE, 225KVA, CU PRIMARY 480 WYE ,SECONDARY 208/120 ZIG ZAG	
DWG# 6312-2170 NO.	

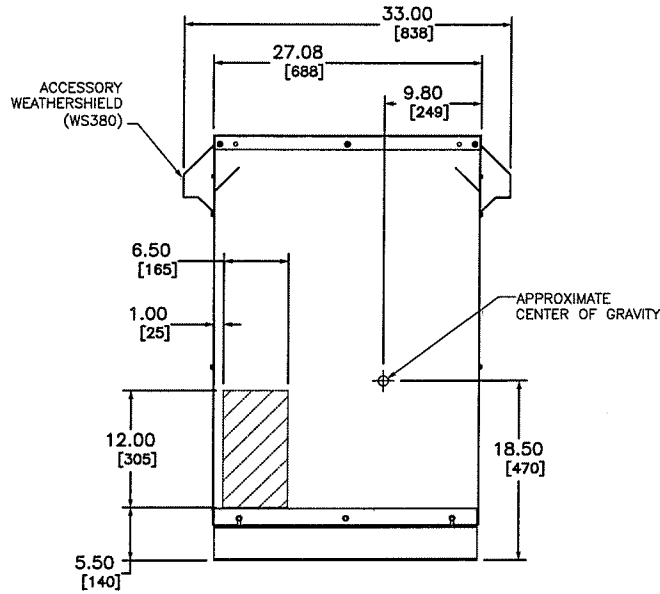
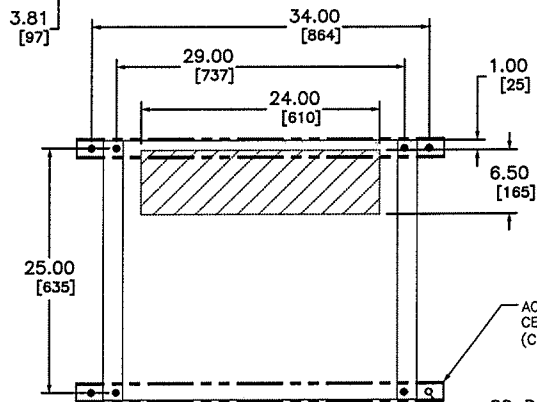
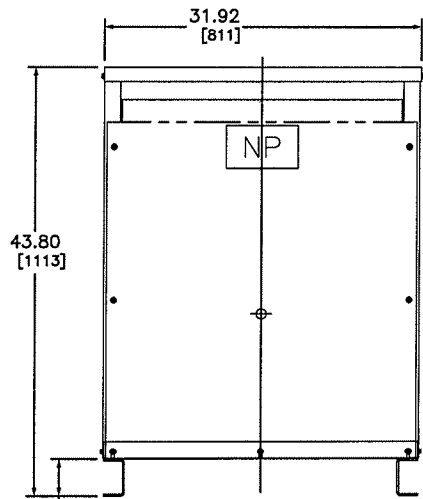

ACCESSORY CEILING MOUNTING BRACKETS (CMB380)

.88 DIA [22] (4 PLS)

IN EACH PHASE CONNECT TO TAPS	
PRIMARY VOLTS	2-2.5% FCAN 4-2.5% FCBN
504	1
492	2
480	3
468	4
456	5
444	6
432	7

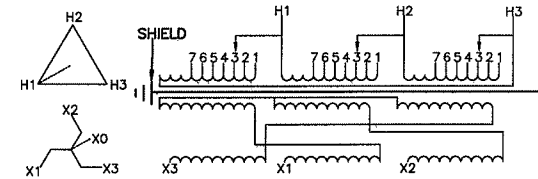

TRANSFORMER SPECIFICATIONS:
 150 KVA 3Ø 60 HZ
 PRIMARY VOLTAGE 480 DELTA
 SECONDARY VOLTAGE 208/120 ZIG ZAG
 150°C RISE ABOVE 40°C AMBIENT
 220°C INSULATION SYSTEM
 COPPER WINDINGS
 APPROXIMATE WEIGHT: 915 LBS
 GUARANTEED SOUND LEVEL: 50 dB
 EFFICIENCY @35%: 98.3% AVG. CONFORMS
 TO NEMA TP 1 - 2002 AND CSA C802.2

NOTES:

- 1) cULus LISTED (MEETING UL 1561 AND CSA C22.2)
- 2) NEMA 2 VENTILATED ENCLOSURE ENCLOSURE RATED FOR NEMA 3R WHEN OPTIONAL WEATHERSHIELD ACCESSORY IS INSTALLED.
- 3) MINIMUM CLEARANCE OF 3.00[76] BETWEEN VENT OPENINGS, WALL OR OTHER OBSTRUCTION
- 4) SHADED AREAS DENOTE CUSTOMER CONDUIT ENTRANCE LOCATIONS, AVAILABLE BOTH SIDES AND BOTTOM

SEISMIC QUALIFICATION:

TO BE COMPLIANT WITH THE SEISMIC REQUIREMENTS OF ASCE/SEI 7, THIS UNIT HAS BEEN QUALIFIED BY SHAKE TABLE TESTING THROUGH SELF CERTIFICATION TO ICC ES AC156. CONTACT YOUR LOCAL SCHNEIDER ELECTRIC/SQUARE D REPRESENTATIVE FOR RELATED QUESTIONS.

DUAL DIMENSIONS: INCHES MILLIMETERS

LOW VOLTAGE HARMONIC MITIGATION
 DRY-TYPE TRANSFORMER
 CATALOG NO. HM150T208NCU
 3 PHASE, 150KVA, CU
 PRIMARY 480 DELTA ,SECONDARY 208/120 ZIG ZAG



DWG# 6312-2172
 NO.

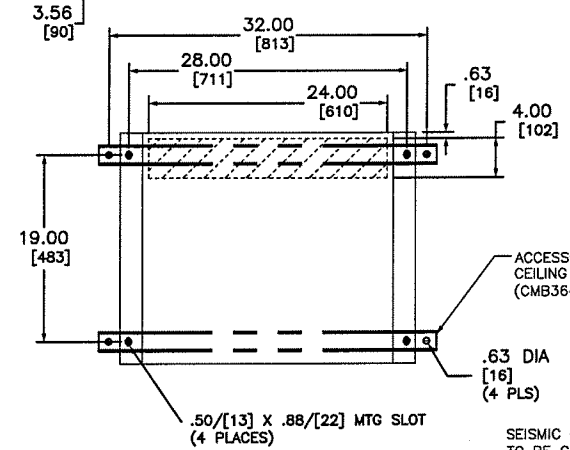
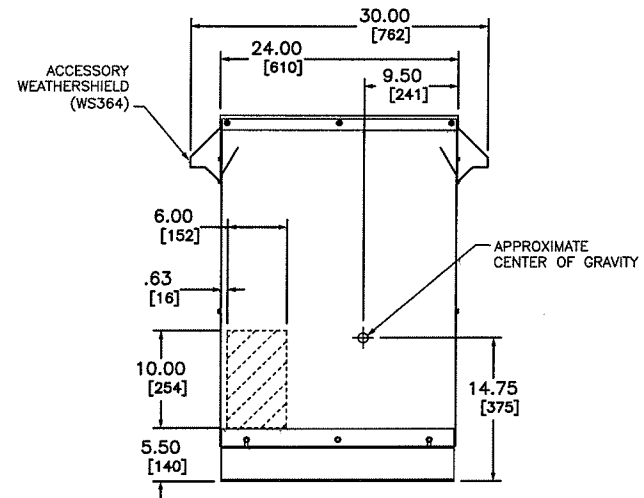
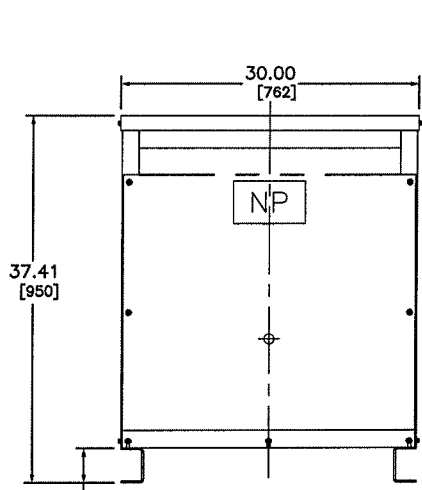

IN EACH PHASE CONNECT TO TAPS	
PRIMARY VOLTS	2-2.5% FCAN 4-2.5% FCBN
504	1
492	2
480	3
468	4
456	5
444	6
432	7

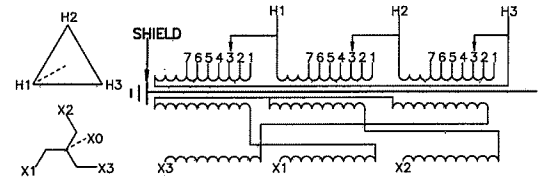

TRANSFORMER SPECIFICATIONS:
 112.5 kVA 3Ø 60 HZ
 PRIMARY VOLTAGE 480 DELTA
 SECONDARY VOLTAGE 208/120 ZIG ZAG
 150 °C RISE ABOVE 40°C AMBIENT
 220 °C INSULATION SYSTEM
 COPPER WINDINGS
 APPROXIMATE WEIGHT: 675 LBS
 GUARANTEED SOUND LEVEL: 50 dB
 EFFICIENCY @35%: 98.2% AVG. CONFORMS
 TO NEMA TP 1 - 2002 AND CSA C802.2

SEISMIC QUALIFICATION:
 TO BE COMPLIANT WITH THE SEISMIC REQUIREMENTS OF ASCE/SEI 7, THIS UNIT HAS BEEN QUALIFIED BY SHAKE TABLE TESTING THROUGH SELF CERTIFICATION TO ICC ES AC156. CONTACT YOUR LOCAL SCHNEIDER ELECTRIC/SQUARE D REPRESENTATIVE FOR RELATED QUESTIONS.

- NOTES:**
- 1) cULus LISTED (MEETING UL 1561 AND CSA C22.2)
 - 2) NEMA 2 VENTILATED ENCLOSURE ENCLOSURE RATED FOR NEMA 3R WHEN OPTIONAL WEATHERSHIELD ACCESSORY IS INSTALLED.
 - 3) MINIMUM CLEARANCE OF 3.00[76] BETWEEN VENT OPENINGS, WALL OR OTHER OBSTRUCTION
 - 4) SHADED AREAS DENOTE CUSTOMER CONDUIT ENTRANCE LOCATIONS, AVAILABLE BOTH SIDES AND BOTTOM

DUAL DIMENSIONS: INCHES
MILLIMETERS

LOW VOLTAGE ENERGY EFFICIENT, TP1
 DRY-TYPE TRANSFORMER
 CATALOG NO HM112T208NCU
 3 PHASE, 112.5 kVA, CU
 PRIMARY 480 DELTA ,SECONDARY 240 DELTA



DWG# 6312-2171
NO.

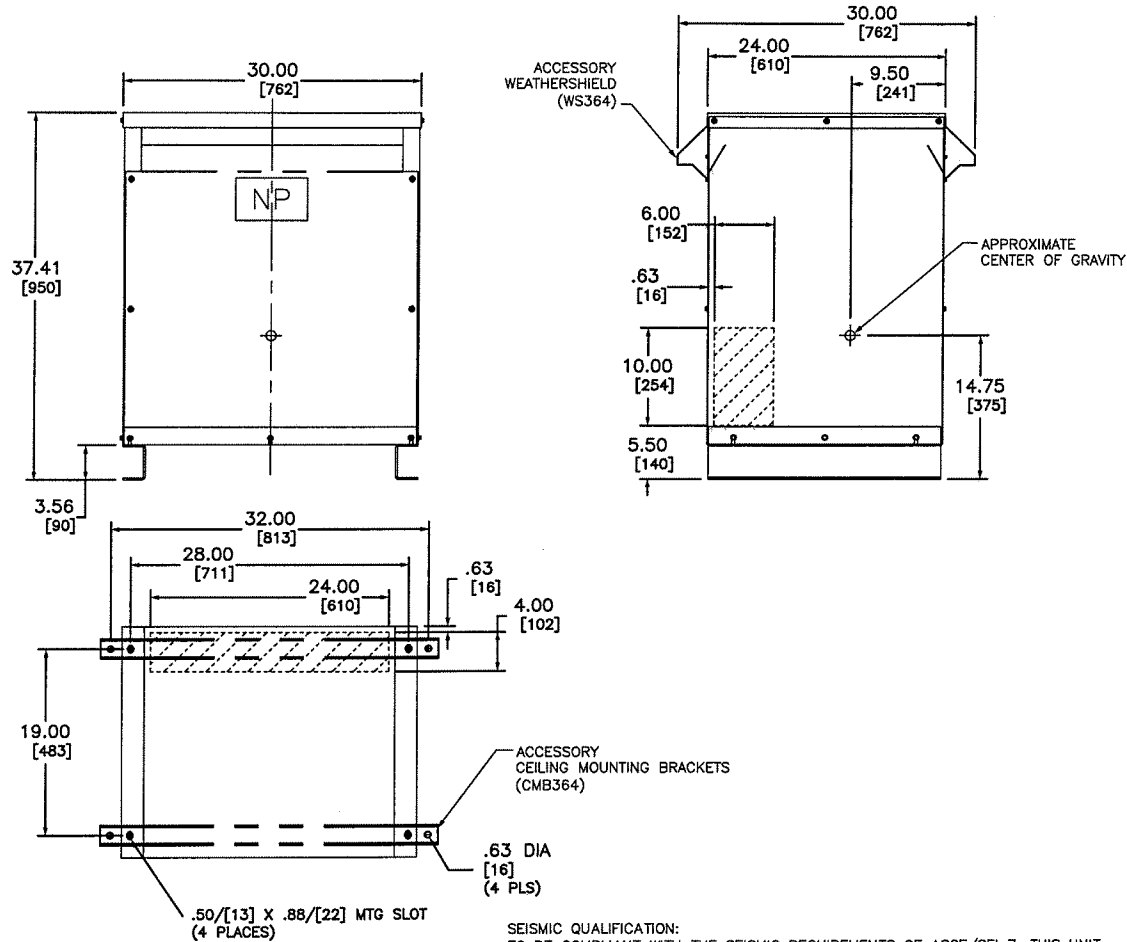

IN EACH PHASE CONNECT TO TAPS	
PRIMARY VOLTS	1-5 %FCAN 2-5 %FCBN
504	1
480	2
456	3
432	4

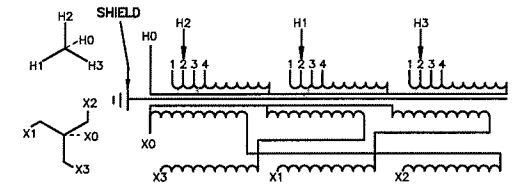

TRANSFORMER SPECIFICATIONS:
 112.5 kVA 3Ø 60 HZ
 PRIMARY VOLTAGE 480 WYE
 SECONDARY VOLTAGE 208/120 ZIG ZAG
 150 °C RISE ABOVE 40°C AMBIENT
 220 °C INSULATION SYSTEM
 COPPER WINDINGS
 APPROXIMATE WEIGHT: 675 LBS
 GUARANTEED SOUND LEVEL: 50 dB
 EFFICIENCY @35%: 98.2% AVG. CONFORMS
 TO NEMA TP 1 - 2002 AND CSA C802.2

- NOTES:
 1) cULus LISTED (MEETING UL 1561 AND CSA C22.2)
 2) NEMA 2 VENTILATED ENCLOSURE
 ENCLOSURE RATED FOR NEMA 3R WHEN OPTIONAL
 WEATHERSHIELD ACCESSORY IS INSTALLED.
 3) MINIMUM CLEARANCE OF 3.00[76] BETWEEN VENT
 OPENINGS, WALL OR OTHER OBSTRUCTION
 4) SHADED AREAS DENOTE CUSTOMER CONDUIT
 ENTRANCE LOCATIONS, AVAILABLE BOTH SIDES
 AND BOTTOM

SEISMIC QUALIFICATION:
 TO BE COMPLIANT WITH THE SEISMIC REQUIREMENTS OF ASCE/SEI 7, THIS UNIT
 HAS BEEN QUALIFIED BY SHAKE TABLE TESTING THROUGH SELF CERTIFICATION TO
 ICC ES AC156. CONTACT YOUR LOCAL SCHNEIDER ELECTRIC/SQUARE D
 REPRESENTATIVE FOR RELATED QUESTIONS.

DUAL DIMENSIONS: INCHES
 MILLIMETERS

LOW VOLTAGE HARMONIC MITIGATION DRY-TYPE TRANSFORMER CATALOG NO HM112T255NCU 3 PHASE, 112.5 kVA, CU PRIMARY 480 DELTA ,SECONDARY 240 DELTA	 DWG# 6312-2171 NO.
--	--

Harmonic Mitigating Transformers

Energy Efficient, Dry Type

Catalog

7400CT0301R7/08

2008

Class 7400

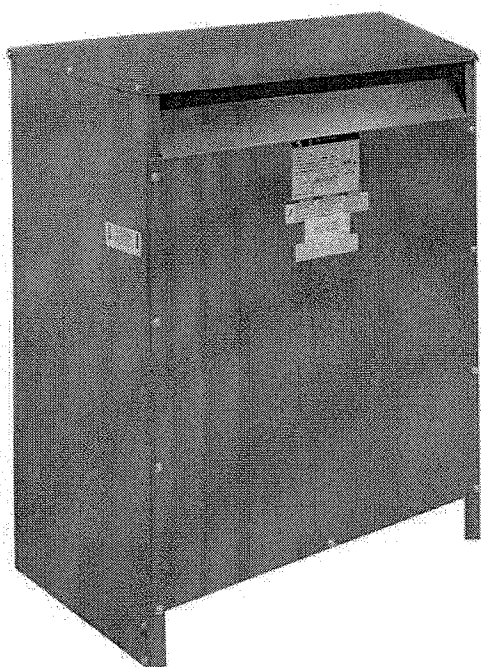

CONTENTS

Description	Page
Product Description	2
General Information	3
Ordering Information	4
Enclosure Diagrams and Accessories	12
Wiring Diagrams	24
NEC Reference: Installing and Connecting Transformers	28
Wire Range Part Numbers and Lug Kits	30
Specifications	32



by Schneider Electric



How Harmonic Mitigating Transformers Address Harmonics

Office Load Harmonic Phase Angle Patterns

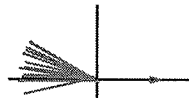

3rd Harmonic

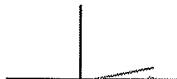

5th Harmonic

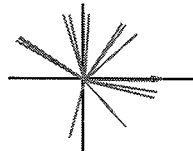

7th Harmonic

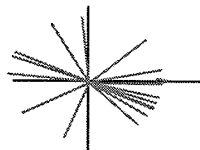

9th Harmonic

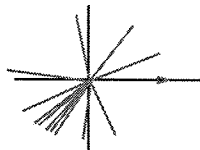

11th Harmonic

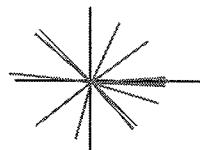

13th Harmonic

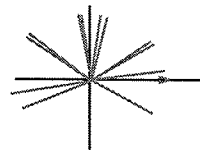

15th Harmonic

- Add Source Impedance (3-5%)
 - Limits Crest Factor
- Phase Shifting
 - 30° Shift (Delta to Wye or Wye to ZigZag)
 - Cancel – Triplen Harmonics (3rd, 9th, 15th, ...)
 - 0° Shift (Delta to ZigZag)
 - Cancel – Triplen Harmonics (3rd, 9th, 15th, ...)

Secondary Current

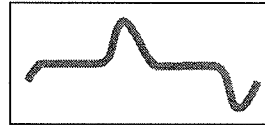

Primary Current

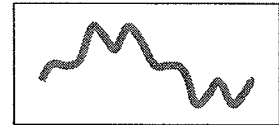

Secondary Current

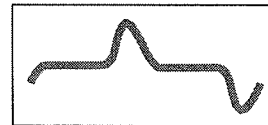

Primary Current

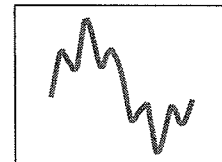

Combination of 30° and 0° with Equal Parallel Runs

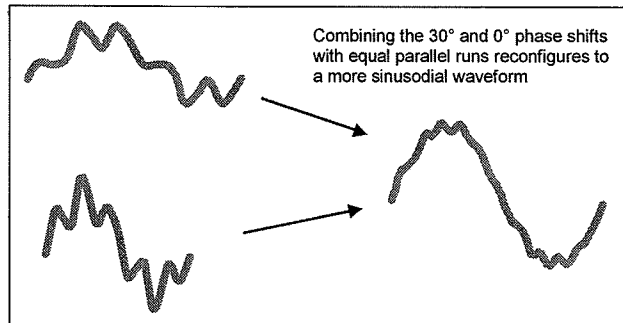

For maximum benefits from harmonic mitigating transformers, both 30° and 0° phase-shift-equivalent products should be incorporated into the system. When this is not possible due to floor space, load requirements, or economic conditions, either product can be incorporated into the system. To combine even more harmonics, the customer can add the +15° or -15°(45°) products to their application.

Another option to maximize the benefits of harmonic mitigating transformers is by tiering them through the system, for example, by using one harmonic mitigating transformer to feed another one.

Schneider Electric recommends using 30° phase-shift, delta to wye transformers in place of wye-zigzag transformers. 30° phase-shift, delta to wye transformers mitigate harmonics, and are widely recognized and accepted throughout the electrical industry.

Harmonic Mitigating Transformers Ordering Information

Ordering Information

Refer to Tables 1–16 for three-phase transformer information. All transformers have copper windings and are rated for a 130 °C temperature rise.

Table 1: 480 V Delta Primary to 208Y/120 V Secondary with a 0° Phase Shift

kVA	Part Number	Enclosure ¹ (Refer to pages 12–23)	Wiring Diagram	Weight Cu (lbs)	Primary Current			Secondary Current	
					Nameplate Rating	NEC Max. Rating 125%	NEC Max. Rating 250%	Nameplate Rating	NEC Max. Rating 125%
15	HM15T208NCU	17D	Figure 1 on page 24	Contact the factory.	18	25	45	41.7	60
30	HM30T208NCU	17D			36.1	45	90	83.3	110
45	HM45T208NCU	18D			54.2	70	125	124.9	175
75	HM75T208NCU	20D			90.3	125	225	208.2	275
112.5	HM112T208NCU	21D			135.5	175	300	312.3	400
150	HM150T208NCU	22D			180.6	225	450	416.4	600
225	HM225T208NCU	24D			271.0	300	600	624.6	800
300	HM300T208NCU	25D			361.3	450	900	832.7	1200

¹ NEMA Type 2 drip-proof enclosure. Weathershields available to upgrade the enclosures to NEMA Type 3R (suitable for outdoor use). Standard transformers up through 75 kVA three-phase and 75 kVA single-phase can be mounted directly on wall via mounting brackets.

Table 2: 480 V Delta Primary to 208Y/120 V Secondary with a +30° Phase Shift

kVA	Part Number	Enclosure ¹ (Refer to pages 12–23)	Wiring Diagram	Weight Cu (lbs)	Primary Current			Secondary Current	
					Nameplate Rating	NEC Max. Rating 125%	NEC Max. Rating 250%	Nameplate Rating	NEC Max. Rating 125%
15	HM15T255NCU	17D	Figure 2 on page 25	Contact the factory.	18	25	45	41.7	60
30	HM30T255NCU	17D			36.1	45	90	83.3	110
45	HM45T255NCU	18D			54.2	70	125	124.9	175
75	HM75T255NCU	20D			90.3	125	225	208.2	275
112.5	HM112T255NCU	21D			135.5	175	300	312.3	400
150	HM150T255NCU	22D			180.6	225	450	416.4	600
225	HM225T255NCU	24D			271.0	300	600	624.6	800
300	HM300T255NCU	25D			361.3	450	900	832.7	1200

¹ NEMA Type 2 drip-proof enclosure. Weathershields available to upgrade the enclosures to NEMA Type 3R (suitable for outdoor use). Standard transformers up through 75 kVA three-phase and 75 kVA single-phase can be mounted directly on wall via mounting brackets.